

The XENON Dark Matter Search Experiment

E. Aprile^{a,*}, K.L. Giboni^a, P. Majewski^a, K. Ni^a,
M. Yamashita^a, R. Gaitskell^b, P. Sorensen^b, L. DeViveiros^b,
L. Baudis^c, A. Bernstein^d, C. Hagmann^d, C. Winant^d,
T. Shutt^e, J. Kwong^e, U. Oberlack^f, D. McKinsey^g, R. Hasty^g

^a*Physics Department and Columbia Astrophysics Laboratory, Columbia University,
New York, NY 10027*

^b*Physics Department, Brown University, Providence, RI 02912*

^c*Physics Department, University of Florida, Gainesville, FL 32611*

^d*Lawrence Livermore National Laboratory, 7000 East Ave., Livermore, CA 94550*

^e*Physics Department, Princeton University, Princeton, NJ 08544*

^f*Physics Department, Rice University, Houston, Texas 77251*

^g*Physics Department, Yale University, New Haven, CT 06520*

Abstract

The XENON experiment aims at the direct detection of dark matter in the form of WIMPs (Weakly Interacting Massive Particles) via their elastic scattering off Xe nuclei. A fiducial mass of 1000 kg, distributed in ten independent liquid xenon time projection chambers (LXeTPCs) will be used to probe the lowest interaction cross section predicted by SUSY models. The TPCs are operated in dual (liquid/gas) phase, to allow a measurement of nuclear recoils down to 16 keV energy, via simultaneous detection of the ionization, through secondary scintillation in the gas, and primary scintillation in the liquid. The distinct ratio of primary to secondary scintillation for nuclear recoils from WIMPs (or neutrons), and for electron recoils from background, is key to the event-by-event discrimination capability of XENON. A dual phase xenon prototype has been realized and is currently being tested, along with other prototypes dedicated to other measurements relevant to the XENON program. As part of the R&D phase, we will realize and move underground a first XENON module (XENON10) with at least 10 kg fiducial mass to measure the background rejection capability and to optimize the conditions for continuous and stable detector operation underground. We present some of the results from the ongoing R&D and summarize the expected performance of the 10 kg experiment, from Monte Carlo simulations. The main design features of the 100 kg detector unit (XENON100), with which we envisage to make up the 1 tonne sensitive mass of XENON1T will also be presented.

Key words: dark matter, WIMP, xenon

1 Introduction

Combined analyses of the latest observational data continue to provide compelling evidence for a significant cold dark matter component in the composition of the Universe (Freedman et al., 2003). While the composition of dark matter is still unknown, WIMPs are a particularly well-motivated dark matter candidate. (Munoz, 2003). Numerous direct and indirect detection experiments have been on-going for decades, and a number of newly proposed projects are being developed (Chardin, 2003).

The contradicting results between an annual modulation signal from the DAMA experiment (DAMA Collaboration, 2003) and the lowest exclusion limits set by the CDMS experiment (CDMS Collaboration, 2004) requires a new generation of dark matter direct search experiments with the sensitivity pushed several orders of magnitude higher.

Efficient and redundant background rejection schemes are a key requirement for these future WIMP experiments, along with the capability to sense nuclear recoil energy depositions as low as a few keV. One of the emerging technologies is to use

liquid xenon (LXe) as the sensitive target. Particle interactions produce both scintillation and ionization signals in LXe, and the distinct ratio of these two signals for nuclear and electron recoil events provides a powerful and efficient background rejection (Yamashita, 2003).

To achieve an increase in sensitivity to $\sim 10^{-46}$ cm² requires a fiducial target mass on the order of 1 tonne, with less than about 10 background events per year. The sensitivity of the current cryogenic experiments will ultimately be limited by the mass of available target, given the technical challenges of scaling well beyond ~ 50 kg. The availability of LXe in large quantities at a reasonable cost, opens the possibility for experiments on the tonne scale. For the XENON (XENON Collaboration, 2001) experiment, we have proposed a mass of 1 tonne distributed in ten LXeTPCs. The design goals are 99.5% background rejection efficiency, achieved by simultaneous measurement of ionization and scintillation signals and an energy threshold of about 16 keV (at which the detector is fully efficient for dark matter detection). Event localization in 3-D and the use of a LXe self-shield provide additional discrimination power. Fig. 1 shows current direct detection dark matter limits along with the projected sensitivity for XENON in its various implementation phases.

* Presented at the 6th UCLA Symposium on *Sources and Detection of Dark Matter and Dark Energy in the Universe*.

Email address:
age@astro.columbia.edu (E. Aprile).

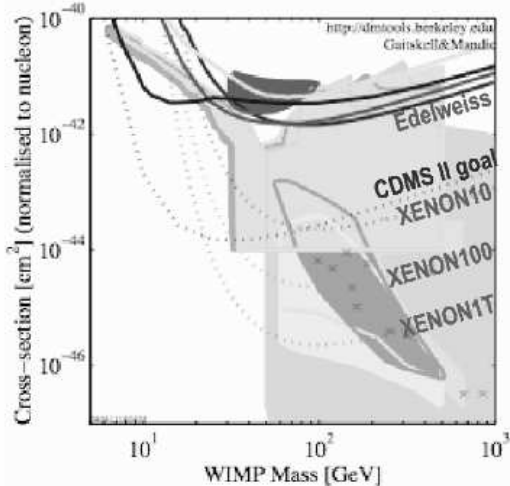

Fig. 1. Current direct detection dark matter limits, along with the projected sensitivity of XENON10, XENON100 and XENON1T.

2 Baseline Detector Design

Fig.2 schematically shows the design of the detector proposed as unit module for the XENON experiment. It is a dual phase TPC, with the active LXe volume defined by a 50 cm diameter CsI photocathode immersed in the liquid, at about 30 cm from the first of three wire grids defining a gas proportional scintillation region. An array of 85 two-inch diameter, UV sensitive PMTs located above the grids, is used to detect both primary and secondary light. The baseline design uses Hamamatsu R9288 Photomultiplier Tubes (PMTs), as in the prototype discussed below, but with selected materials for low radioactivity.

The TPC is enclosed in a leak-tight cylindrical structure made of PTFE and OFHC. The PTFE is used as effective UV light reflector (Yamashita, 2004) and as electrical

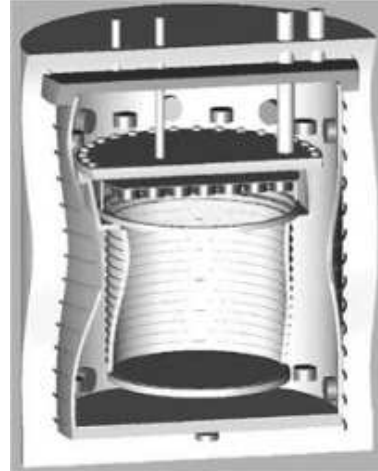

Fig. 2. Schematic view of the XENON 100 dual phase detector.

insulator. The fraction of direct light heading downward will be efficiently detected with the CsI photocathode (Aprile, 1994b). The whole structure is immersed in a bath of LXe, serving as active veto shield against background. The LXe for shielding is contained in a double wall vacuum cryostat, made of stainless steel and is cooled by a pulse tube refrigerator. An array of 64 PMTs are mounted on the walls of the cryostat, fully immersed in LXe to detect the direct scintillation light from the shield. With both target and shield Xe volumes kept at the same temperature and pressure, the thickness of the vessel enclosing the TPC can be minimized. The amount of active Xe in the TPC is about 180 kg. With fiducial volume cuts applied for background reduction to the level required for a sensitive WIMP search, the active target is reduced to about 120 kg, hence we refer to this unit module as XENON100. Clearly, if the dominant radioactivity from the PMTs is reduced, we will recover a larger fraction of the active target

for a WIMP search.

An event in the XENON TPC will be characterized by three signals corresponding to detection of direct scintillation light, proportional light from ionization electrons and CsI photoelectrons. Since electron diffusion in LXe is small, the proportional scintillation pulse is produced in a small spot with the same X-Y coordinates as the interaction site, allowing 2D localization with an accuracy of 1 cm. With the more precise Z information from the drift time measurement, the 3D event localization provides an additional background discrimination via fiducial volume cuts. The simulated detection efficiency of the primary scintillation light is about 5 p.e./keV for the XENON 100 detector.

3 Current Results from the XENON R&D Phase

The XENON R&D program is being carried out with various prototypes dedicated to test several feasibility aspects of the proposed concept, and to measure the relevant detector characteristics. Here we limit the discussion to the results obtained to-date with a dual phase xenon prototype with ~ 3 kg of active mass. The primary scintillation light ($S1$) from the liquid, and the secondary scintillation light ($S2$) from the ionization electrons extracted into the gas phase, are detected by an array of seven PMTs, operating in the cold gas above the liquid. Excellent discrimination between alpha particles

and gamma-ray events was achieved with this prototype chamber. We are currently upgrading the detector light readout system to be able to measure low energy nuclear recoils.

3.1 Set Up and DAQ System

A drawing of the TPC prototype is shown in Fig. 3 while the photo of Fig. 4 shows the detector integrated with the vacuum cryostat, refrigerator, gas/recirculation system, and electronics for control and data taking. The detector is cooled by a Pulse Tube Refrigerator (PTR), optimized for LXe temperature.

The sensitive volume of the TPC ($7.7 \times 7.7 \times 5.0$ cm³) is defined by PTFE walls and grids with high optical transmission, made of Be-Cu wires with a pitch of 2 mm and $120 \mu\text{m}$ diameter. Negative HV is applied to the bottom grid, used as cathode. Grids on the top close the charge drift region in the liquid and with appropriate biasing, create the amplification region for gas proportional scintillation. Shaping rings located outside of the PTFE walls and spaced 1.5 cm apart, are used to create a uniform electric field for charge drift.

To study the electric field, calculations were carried with the Maxwell and Garfield computer programs. The result is shown in Fig. 5. At the drift field of 1 kV/cm, the loss of charges due to drift lines ending-up on the PTFE walls and bottom is minimal. The calculation also veri-

fied that the presence of the ^{210}Po source disk, soldered to the cathode grid wires, does not significantly distort the field lines to affect the drift of ionization electrons produced by the external gamma-ray source.

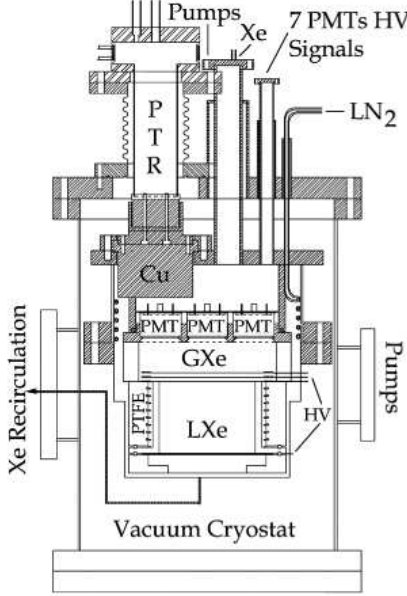

Fig. 3. Schematic drawing of the dual phase prototype.

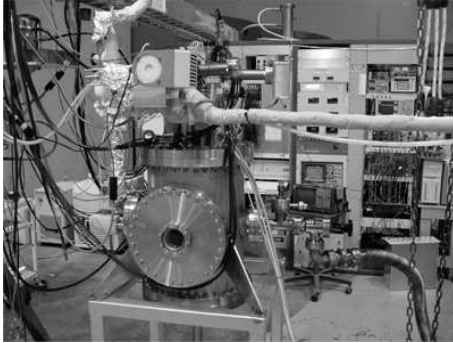

Fig. 4. The detector integrated with the vacuum cryostat, refrigerator, gas/recirculation and DAQ systems.

Seven Hamamatsu R9288 PMTs are installed on the top flange, resting on a PTFE support. We used LEDs to measure the PMTs gain and single photoelectron response. Additional PMTs or a CsI photocathode will be used in subsequent tests to increase

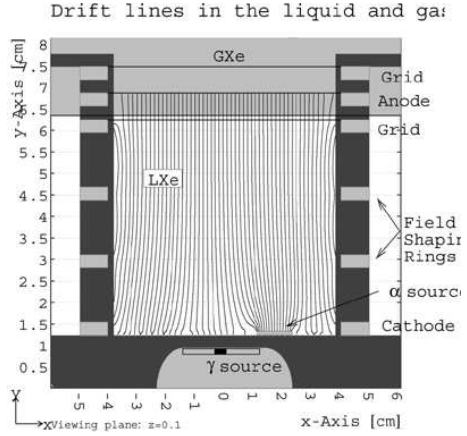

Fig. 5. Electric field distribution for the dual phase prototype.

light collection. The chamber was successfully operated during several long runs, lasting up to 2 weeks, to test the cryogenics system reliability, the efficiency of the gas purification/recirculation and to optimize the dual phase response with both gamma-rays and alpha particles.

The primary scintillation light from LXe was recorded by a charge integrating ADC with a 12 bit resolution. A CAMAC waveform digitizer with 8 bit resolution was used to record the secondary scintillation light produced in the amplification gap by the ionization electrons extracted from the liquid to the gas. The coincidence of more than one PMT signals was required to create a trigger. We are upgrading the DAQ system to digitize both primary and secondary light pulses.

3.2 Purification and Recirculation System

To meet the stringent LXe purity requirement for this type of detector,

we have developed a gas purification and recirculation system capable to remove electronegative impurities from the liquid filled detector: xenon gas is continuously extracted from the detector and circulated through a high temperature getter (SAES), before being re-condensed (Mihara, 2004). The charge collection efficiency depends on the electron lifetime in LXe. We have achieved a lifetime longer than $500 \mu s$ after a few days of continuous purification (see Fig. 6). Details of the purification/recirculation system are described elsewhere (Aprile, 2004).

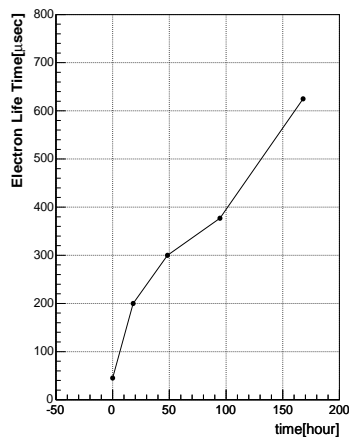

Fig. 6. The electron life time as a function of purification time. Time zero indicates the start of the recirculation.

3.3 Discrimination of Gamma-Rays and Alpha Particles

Fig. 7 shows the ratio of light yields $S1$ (primary) and $S2$ (secondary) measured with the dual phase prototype, under simultaneous irradiation with 122 keV gamma rays from ^{57}Co and with 5.3 MeV alpha particles from ^{210}Po . The detector was operated at 1 kV/cm in the drift region

and 10 kV/cm in the gas region. The ratio is normalized to that of gamma rays. The alpha and electron recoils are clearly separated by a factor of about 30. This factor can be even larger, if we account for the fraction of primary light produced by alpha recoils which is absorbed by the ^{210}Po source disk

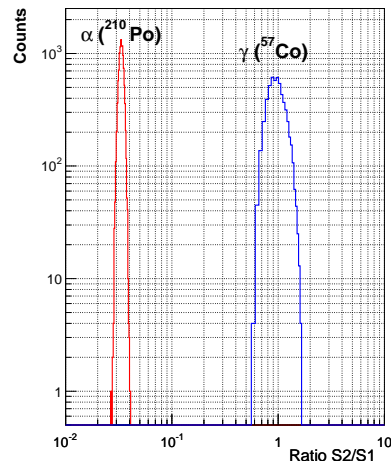

Fig. 7. The ratio $S2/S1$ for 122 keV gamma rays and 5.3 MeV alpha particles. The distributions are normalized to the peak from gamma rays.

3.4 Energy Detection Threshold

The energy detection threshold of the current prototype is limited by the poor primary light collection efficiency, mainly due to total reflection of scintillation light at the liquid-gas interface. From Monte Carlo simulations the light collection efficiency is 0.3 p.e./keV, consistent with experimental results obtained with this detector. To increase light collection and lower the minimum energy threshold, we need to cover the bottom of the detector with light sensors. In the original XENON proposal (XENON Collaboration, 2001), we

suggested to use a CsI photocathode at the bottom of the LXe drift volume. Simulations show that with the cathode covered by a thin CsI layer, the primary light collection efficiency of the current prototype would increase to 7.7 p.e./keV, thanks to the high QE and large coverage of the CsI photocathode (Aprile, 1994a). The light collection efficiency can also be improved by placing PMTs below the cathode. With 16 Hamamatsu R8520 1" square PMTs on the bottom, we estimate a light collection efficiency of 2.6 or 2.3 p.e./keV, with or without the seven top PMTs. This level is sufficient to achieve the low energy detection threshold required for a sensitive WIMP search, and will be our next upgrade of this prototype prior to realizing the XENON10 module for tests underground.

4 Background Simulations

The XENON10 dark matter detector prototype, will be deployed at a deep site by the end of 2005. For a WIMP of 100 GeV, the sensitivity goal for XENON10 is a normalized cross-section of 2×10^{-44} cm². This corresponds to an interaction rate of ~ 16 events/10 kg/yr, and a low energy WIMP differential event rate of $\sim 7 \times 10^{-4}$ /keVee/kg/day, for a detection threshold of 8 keVee (16 keV nuclear recoil). A nuclear recoil quenching factor of 50% is used, to reflect the high field operation (> 1 kV/cm) of the detector.

In the Monte Carlo simulations of the XENON10 background rate, we use

this sensitivity as the goal in defining upper limits for acceptable backgrounds, although in many cases the projected background rates are well below this level. The sensitivity goal for the subsequent XENON100 module is estimated to be a factor 10 better than XENON10. In this paper we focus on the XENON10 projections.

The overall background event rate in the detector is contributed by both internal and external sources of gamma rays and neutrons. The total gamma interaction rate in the fiducial volume needs to be < 0.14 evts/keV/kg/day. This goal is based on a projected discrimination (electron versus nuclear recoils) of at least 99.5% using the ratio of primary to secondary scintillation light yield.

The model of the XENON10 prototype used in the simulations consists of a cylindrical LXe volume with 17.5 cm diameter and 15 cm depth. The LXe of the fiducial volume is surrounded by an additional LXe layer, 5 cm thick, operated as active anticoincidence shield. The number of PMTs viewing the inner target and the outer shield are 7 and 16, respectively. The U/Th/K activity of the PMTs is assumed to be 13/4/60 mBq/PMT. The numbers reflect the measurements reported to-date by Hamamatsu. We note that the company continues to optimize the choice of materials used in the PMTs construction and expects to further reduce the activity level in the near future. We also note that the high K activity is not a concern because it contributes $< 3\%$ to the low energy gamma background, relative to

U/Th of the same activity. A common vessel made of stainless steel is assumed to contain both the target and shield LXe. Monte Carlo results show that steel (62 kg) at a level of activity of 30 mBq/kg (assumed dominated by ^{60}Co) will allow us to comfortably beat ($> 100\times$) the target gamma rate in the inner fiducial region. The result shown in Fig. 8 includes event rejection by the active anti-coincidence LXe shield and by requiring only single-sited events in the fiducial volume, as expected from WIMP interactions.

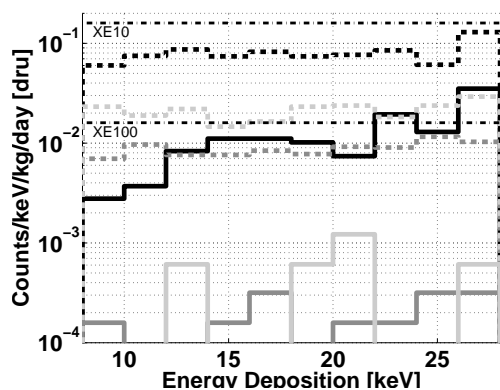

Fig. 8. Monte Carlo event rates in XENON10 arising from 7 \times inner PMTs (black), 16 \times outer PMTs (dark gray) and stainless pressure vessel (light gray). The dashed lines are the raw rates, and the solid lines show rates after rejecting multiple site events in the inner LXe, and after the anti-coincidence with the outer LXe shield. The horizontal dot-dash lines indicate the goals for gamma event rates for the XENON10 and XENON100 modules.

Fig. 8 summarizes the low energy spectra (evts/keVee/kg/day) of gamma events from the inner and outer PMTs and the stainless steel pressure vessel. ^{85}Kr contamination in the Xe will produce a flat spectrum

in the energy region shown in Fig. 8 at a level of 1 evts/keVee/kg/day/30 ppb Kr. Kr will be removed from the Xe to levels well below $\ll 1$ ppb using charcoal column separation technology being developed by the collaboration.

The gamma activity from the underground cavern will be attenuated using a 22 cm Pb shield. Pb with an activity of ^{210}Pb of 6 Bq/kg can be used for the inner liner (~ 5 cm) of the Pb shield as its effect is reduced by the 5 cm LXe shield.

The (α, n) neutrons, in the energy range 0.1–8 MeV, arising from U/Th α 's in the rock can be attenuated below the desired level by 60 cm of polyethylene moderator. Although the underground site has not yet been selected, this projection assumes a representative flux of 4×10^{-6} /cm²/s. The contribution to the neutron background from the internal U/Th content within the shield has also been simulated and shown to be comfortable subdominant.

Cosmic ray muons contribute electromagnetic backgrounds through direct interaction in the detector and surrounding shield, and also through the generation of neutrons in the shield and surrounding rock. A 2" plastic scintillator veto completely surrounding the Pb/polyethylene shield will be able to tag muons entering the entire shield volume with $> \sim 99\%$ efficiency, decreasing the muon associated signals to subdominant level at depths $> \sim 2000$ mwe. High energy neutrons (10-2000 MeV) created in the rock by muons

are not significantly attenuated by the moderator shield, and generate high multiplicity events within the Pb shield. Depth is the most effective way to decrease the signal from these "punch-through" neutrons. Simulations show that the event rate from these punch-through neutrons is reduced below the XENON10 goal at a depth larger than 2000 mwe. A deeper location ($>\sim 3700$ mwe) will be required to achieve the projected sensitivity of XENON100.

5 Acknowledgment

This work is supported by a grant from the National Science Foundation to the Columbia Astrophysics Laboratory (Grant No. PHY-02-01740). The Brown University group is also supported by an Outstanding Junior Investigator award from the Department of Energy. One of the authors (P. Majewski) acknowledges the support by the North Atlantic Treaty Organization under a grant awarded in 2003.

References

- Aprile, E., et al., Nucl. Inst. Meth. A 338 (1994a) 328.
- Aprile, E., et al., Nucl. Inst. Meth. A 343 (1994b) 129.
- Aprile, E., et al., IEEE NSS MIC SNPS RTSD (2004) (submitted)
- CDMS Collaboration, astro-ph/0405033.
- Chardin, G., astro-ph/0306134.
- DAMA Collaboration, Riv. N. Cim. 26 n.1 (2003) 1-73, also at astro-ph/0307403.
- Freedman, W.L. and Turner, M.S., Rev. Mod. Phys. 75 (2003) 1433-1447. Ansoft.
- Mihara, S., et al., Cryogenics, 44 (2004) 223-228.
- Munoz, C., hep-ph/0309346.
- SAES Pure GAS, Inc. <http://www.saesgetters.com/>.
- XENON Collaboration, NSF proposal number 0201740, 'XENON: A Liquid Xenon Experiment for Dark Matter', proposal submitted to NSF, Particle and Nuclear Astrophysics in Sep. 2001.
- XENON Collaboration, p.165, Proceedings of the International Workshop on Techniques and Applications of Xenon Detectors, ICRR, Univ. of Tokyo, Kashiwa, Japan, held December 2001, also at astro-ph/0207670.
- Yamashita, M., et al., Astropart. Phys., 20 (2003) 79-84.
- Yamashita, M., et al., Nucl. Inst. and Meth. A (2004, in press).